



COUNTY GOVERNMENT OF NYANDARUA

DEPARTMENT OF PUBLIC WORKS, ROADS, TRANSPORT,
HOUSING & ENERGY

PROPOSED ERECTION AND COMPLETION OF RADIOLOGY UNIT AT NDARAGWA
HEALTH CENTRE

FOR

HEALTH SERVICES

BILL OF QUANTITIES

ARCHITECT,
COUNTY ARCHITECT,
DIR. OF PUBLIC WORKS,
NYANDARUA COUNTY,
P.O. BOX 701 - 20303
OL KALOU

QUANTITY SURVEYOR,
COUNTY QUANTITY SURVEYOR,
DIR. OF PUBLIC WORKS,
NYANDARUA COUNTY,
P.O. BOX 701 - 20303
OL KALOU

ELEC/MECH ENGINEER
COUNTY ELEC / MECH. ENGINEER,
DIR. OF PUBLIC WORKS,
NYANDARUA COUNTY,
P.O. BOX 701 - 20303
OL KALOU

STRUCTURAL ENGINEER,
COUNTY ENGINEER - STRUCTURAL
DIR. OF PUBLIC WORKS,
NYANDARUA COUNTY,
P.O. BOX 701 - 20303
OL KALOU

FEBRUARY, 2023

FORM OF TENDER

TO: _____ [Date] _____

Dear Sir,

1 In accordance with the Conditions of Contract, Specifications, Drawings and Bills of Quantities for the execution of the above named Works, we, the undersigned offer to construct, install and complete such Works and remedy

any defects therein for the sum of Kshs. _____ [Amount in figures] Kenya Shillings _____

_____ [Amount in words]

2 We undertake, if our tender is accepted, to commence the Works as soon as is reasonably possible after the receipt of the Project Manager's notice to commence, and to complete the whole of the Works comprised in the Contract within _____ Weeks

3 We agree to abide by this tender until *120 days from date of tender*, and it shall remain binding upon us and may be accepted at any time before end of the said days

4 Unless and until a formal Agreement is prepared and executed this tender together with your written acceptance thereof, shall constitute a binding Contract between us.

5 We understand that you are not bound to accept the lowest or any tender you may receive.

Dated this _____ day of _____ 20 _____

Signature _____ in the capacity of _____

Duly authorized to sign tenders for and on behalf of

_____ [Name of the Tenderer]

of _____ [Address of the tenderer]

Witness; Name _____

Address _____

Signature _____

Date _____

BUILDER'S WORK

PROPOSED ERECTION AND COMPLETION OF RADIOLOGY UNIT AT NDARAGWA HEALTH CENTRE

Item	Description of Works	Unit	Qty	Rate	Amount (Kshs)
	<p><u>ELEMENT NO. 01 - PRELIMINARIES</u></p> <p>The Contractor is to allow for all Preliminaries including site offices and stores, transport of workmen to and from site, transport of materials, supply, setting out, servicing, fueling of the plant and equipment, provision of plant operator, insurance for the works shall be the sole responsibility of the contractor and all other preliminaries incidental to these works</p>				
A	Allow for all Preliminaries associated with the works	Item	1		
	<p><u>NEMA APPROVALS</u></p> <p>The Contractor's attention is drawn to legal notice for the Environment Management and Coordination Act (EMCA), 1999 (Amendment 2015) as aligned with the constitution of Kenya 2010 and the Authority re-introduction of a processing and monitoring EIA and SEA reports with effect from 1st June 2022. The act and regulations require developers to undertake requisite environmental impact and social impact assessments for projects, the notice requires proponents of projects to pay 0.1% of the total cost of projects with a minimum of ten thousands(10,000) shillings as an EIA processing and monitoring fees effective 1st June 2022</p>				
B		Item	1		
	<p><u>TRAINING LEVY</u></p> <p>The Contractor's attention is drawn to legal notice No. 237 of October, 1971, which requires payment by the Contractor of a Training Levy at the rate of 1/4 % of the Contract sum on all contracts of more than Kshs. 50,000.00 in value.</p>				
C		Item	1		
	Element 01				
	PRELIMINARIES		CARRIED TO SUMMARY	KSHS	

PROPOSED ERECTION AND COMPLETION OF RADIOLOGY UNIT AT NDARAGWA HEALTH CENTRE

Item	Description of Works	Unit	Qty	Rate	Amount (Kshs)
	ELEMENT 02 SUBSTRUCTURE [ALL PROVISIONAL]				
	Site Clearance				
A	Clear site of all grass, bushes, undergrowth, scrubs, hedges and the like, cut down trees not exceeding 600 mm girth, grub up roots, and heap all arising debris on site approximately (200 mm away) as directed by the Project Manager	SM	193		
	Excavation including maintaining and supporting sides and keeping free from water, mud and fallen materials				
	Bulk excavations				
B	- not exceeding 1.50 metres deep For foundations commencing at reduced level	CM	193		
C	- not exceeding 1.5 metres deep For column bases commencing at reduced level	CM	112		
D	- not exceeding 1.5 metres deep	CM	4		
E	Extra over for excavating in soft/hard rock	CM	12		
	Disposal				
F	Backfilling to make up levels	CM	22		
G	Load and and heap all arising on site approximately (200 mm away) as directed by the Architect	CM	94		
	Imported filling				
H	Approved filling to make up levels	CM	154		
	Blinded hardcore bed to receive concrete, thickness				
I	- 300 mm	SM	51		
	Damp - proof membranes				
J	1000 Gauge polythene laid under surface beds	SM	181		
	Anti - termite treatment				
K	Chemical anti - termite treatment executed by an approved specialist under a ten - year guarantee to surfaces of hardcore, etc.	SM	181		
	Plain concrete 1:4:8				
	Blinding under foundations and columns, thickness				
L	- 50 mm	SM	75		
	Element 02				
	Substructure (All Provisional)	Carried Forward		Kshs.	

PROPOSED ERECTION AND COMPLETION OF RADIOLOGY UNIT AT NDARAGWA HEALTH CENTRE

Item	Description of Works	Unit	Qty	Rate	Amount (Kshs)
	Brought Forward			Kshs.	
	Vibrated reinforced concrete class 25				
A	Foundations	CM	14		
B	Columns	CM	1		
C	Ground Beam	CM	11		
	Beds, thickness				
D	- 200 mm	SM	181		
	Reinforcement				
	High yield deformed steel bar reinforcement to B.S. 4461				
E	- 8mm Diameter bars	Kg	703		
F	- 10mm Diameter bars	Kg	608		
G	- 12mm Diameter bars	Kg	652		
H	- 16 - 32mm Diameter bars	Kg	886		
	Steel mesh fabric reinforcement to B.S. 4483				
	Layer of mesh fabric reinforcement laid in slab or bed (measured nett - no allowance made for laps)				
I	- Ref.A142 weighing 2.22 kgs per square metre	SM	181		
	Lined Fair Face Formwork				
J	Sides of foundations, bases, etc.	SM	47		
K	Sides of Columns	SM	6		
	Edges of beds, etc.				
L	- 150 to 225 mm	LM	55		
	Natural Stone walling in cement mortar				
	Walling				
M	- 200 mm	SM	236		
N	- 300 mm	SM	56		
	Cement and sand (1:5) rendering				
	Rendering to plinths finished with a steel trowel, thickness				
O	- 12 mm	SM	22		
	Prepare and apply two coats bituminous paint				
P	Rendered walls	SM	22		
	Element 01				
	Substructure (All Provisional)	Carried to Summary		Kshs.	

PROPOSED ERECTION AND COMPLETION OF RADIOLOGY UNIT AT NDARAGWA HEALTH CENTRE

Item	Description of Works	Unit	Qty	Rate	Amount (Kshs)
	ELEMENT 03 R. C. SUPERSTRUCTURE				
	Vibrated reinforced concrete class 25				
A	Beams	CM	7		
	Suspended slabs, thickness				
B	- 200 mm	SM	34		
	Reinforcement (All Provisional)				
	High yield deformed steel bar reinforcement to B.S. 4461				
C	- 8mm Diameter bars	Kg	470		
D	- 10mm Diameter bars	Kg	789		
E	- 12mm Diameter bars	Kg	645		
	Lined Fair Face Formwork				
F	Soffits of slabs	SM	34		
G	Sides and soffits of beams	SM	94		
	Element 03				
	R. C. Superstructure	Carried to Summary		Kshs.	

PROPOSED ERECTION AND COMPLETION OF RADIOLOGY UNIT AT NDARAGWA HEALTH CENTRE

Item	Description of Works	Unit	Qty	Rate	Amount (Kshs)
	ELEMENT 04 WALLING				
	External Walling				
	Machine cut stone walling in cement mortar (1:4) with neat raked horizontal joints				
	External walling reinforced with hoop iron at each and every alternate course, thickness				
A	- 300 mm	SM	20		
B	- 200 mm	SM	103		
	Machine cut stone walling in cement mortar				
	Internal walling reinforced with hoop iron at each and every alternate course, thickness				
	Walling reinforced as described,				
C	- 300 mm	SM	36		
D	- 200 mm	SM	60		
E	- 200 mm - Gable Walls	SM	37		
F	- 150 mm	SM	4		
G	'Extra over [Item: A & C] 1.6mm thick anti-radiation lead plates infill	SM	56		
	Lead Glass Screen				
	27mm Lead glass screen with and including 100 x 50x 2mm Aluminium framing and glazing beads fixed to X-ray Operator window, to Architect's Details	SM	1		
	Bituminous felt damp proof courses laid on and including leveling screed of cement mortar				
	In walling , width				
I	- 200 mm	LM	117		
	Element 04				
	Walling	Carried to Summary		Kshs.	

PROPOSED ERECTION AND COMPLETION OF RADIOLOGY UNIT AT NDARAGWA HEALTH CENTRE

Item	Description of Works	Unit	Qty	Rate	Amount (Kshs)
	ELEMENT 05 ROOFING & RAINWATER DISPOSAL				
	28 Gauge prepainted galvanised mini corrugated mild steel sheet				
	Roof sheeting laid with 94 mm side laps and 200 mm end laps fixed to timber purlins with and including roofing screws, washers and caps at centres				
A	- 1200 mm	SM	241		
B	Raking cutting on sheeting	LM	32		
	Ridge sheeting , girth				
C	- 600 mm	LM	32		
	Sawn cypress (Grade 1) treated as described (provisional)				
	The following in structural members in trusses including bolts , cleats , hoisting , etc.,				
	Truss No. 1 (8No.)				
	Rafters and ties				
D	- 150 x 50 mm	LM	122		
	Struts and ties				
E	- 100 x 50 mm	LM	190		
	Ceiling Joist				
F	- 150 x 50 mm	LM	98		
	Truss No. 2 (3No.)				
	Rafters and ties				
G	- 150 x 50 mm	LM	100		
	Struts and ties				
H	- 100 x 50 mm	LM	112		
	Ceiling Joist				
I	- 150 x 50 mm	LM	78		
	Wall plates plugged bolted (bolts and holes measured separately)				
J	-100 x 50 mm	LM	117		
	Ridge				
K	- 150 x 50 mm	LM	17		
	Element 05				
	Roofing & Rainwater Disposal	Carried Forward		Kshs.	

PROPOSED ERECTION AND COMPLETION OF RADIOLOGY UNIT AT NDARAGWA HEALTH CENTRE

Item	Description of Works	Unit	Qty	Rate	Amount (Kshs)
				Kshs.	
	Brought Forward				
A	Purlins - 50 x 50 mm	LM	450		
	Wrought cypress treated as described				
B	Fascia and bargeboard - 300 x 38 mm	LM	60		
	UPVC Pipes & Gutters				
C	UPVC Pipes jointed with hemp gasket and cold caulking compound and fixed to walls with brackets @ 300mm c/c, size - 150 mm diameter	LM	12		
	Extra for offset in pipe , size				
D	- 100 x 100 mm	No.	4		
	Extra for shoe in pipe , diameter				
E	- 100 x 100 mm	No.	4		
	UPVC gutter half round, fixed to fascia board with brackets @ 300mm c/c, size				
F	- 100 mm diameter	LM	32		
	Extra for angle in gutter , size				
G	- 150 x 150 mm	No.	4		
	Knot, prime, stop and apply two undercoats and one gloss finishing coat paint to woodwork				
	Surfaces				
H	- 200 to 300 mm girth	LM	60		
	Element 05				
	Roofing & Rainwater Disposal	Carried to Summary		Kshs.	

PROPOSED ERECTION AND COMPLETION OF RADIOLOGY UNIT AT NDARAGWA HEALTH CENTRE

Item	Description of Works	Unit	Qty	Rate	Amount (Kshs)
	ELEMENT 06 EXTERNAL FINISHES				
	Cement and sand (1:4) rendering				
	Rendering to concrete surfaces finished with a wood float thickness				
A	- 15 mm	SM	17		
B	Ditto to reveals	SM	5		
	Prepare and apply three coats exterior quality 'permaplast' paint				
C	Rendered concrete surfaces externally	SM	17		
D	Rendered walls reveals	SM	5		
	Element 06				
	External Finishes	Carried to Summary		Kshs.	

PROPOSED ERECTION AND COMPLETION OF RADIOLOGY UNIT AT NDARAGWA HEALTH CENTRE

Item	Description of Works	Unit	Qty	Rate	Amount (Kshs)
	ELEMENT 07 INTERNAL FINISHES				
	Lime Plaster				
A	Plaster to walls	SM	323		
B	Plaster to sides and soffits of beams	SM	94		
C	Plaster to soffits of slabs	SM	34		
D	Plaster to reveals of openings	SM	5		
	Porcelain floor and wall tiles				
	Supply and and fix Porcelain floor Tiles including bedding in approved adhesive and pointing in tinted cement (Supply only @ Kshs. 1,500/SM Ex - hardware price)	SM	181		
	Ditto Skirting				
F	- 100 mm high	LM	129		
	Supply and and fix Wall Tiles including bedding in approved adhesive and pointing in tinted cement including conner (Supply only @ Kshs. 1,200/SM Ex - hardware price)	SM	44		
	Cement and Sand [1:4] beds and backings				
	Beds to receive flooring, etc., finished with a steel trowel, thickness				
H	32 mm thick	SM	181		
	Backing to tile dados, etc., thickness				
I	- 12 mm	SM	44		
	Prepare and apply three coats plastic emulsion paint				
J	Plastered walls	SM	323		
K	Plastered sides & soffits of beams	SM	94		
L	Plastered soffits	SM	34		
M	Plastered reveals of openings	SM	5		
	Element 07				
	Internal Finishes	Carried to Summary		Kshs.	

PROPOSED ERECTION AND COMPLETION OF RADIOLOGY UNIT AT NDARAGWA HEALTH CENTRE

Item	Description of Works	Unit	Qty	Rate	Amount (Kshs)
	ELEMENT 08 WINDOWS				
	Windows cill				
	Precast Concrete to approval				
A	150 x 25 mm cill, bedded and jointed in cement and sand 1:1 and pointed in tinted cement	LM	8		
	Steel Casement Windows				
	Purpose made casement windows with permanent ventilating units, manufactured from 20 x 20 x 3 mm 'Z' and 'T' mild steel sections including and complete with heavy duty brass stays and fasteners fixed to masonry jambs and concrete head				
	Window , overall size				
B	- 1500 x 1500 mm	No	3		
C	- 750 x 750 mm	No	2		
	Clear/Obscure sheet glass				
	4 mm Glass and glazing to metal with putty in panes				
D	- 0.50 to 1.00 square metres	SM	8		
	Prepare, prime and apply two undercoats and one gloss finishing coat oil paint to metal				
E	Windows (both sides measured overall)	SM	16		
	Element 08				
	Windows	Carried to Summary		Kshs.	

PROPOSED ERECTION AND COMPLETION OF RADIOLOGY UNIT AT NDARAGWA HEALTH CENTRE

Item	Description of Works	Unit	Qty	Rate	Amount (Kshs)
	ELEMENT 09 DOORS				
	Flush doors to B.S. 459 [Part 2]				
	50 mm Solid core flush doors faced both sides with 6 mm plywood zen veneered for polishing , moulded and hardwood lipped all round, size				
A	- 900 x 2700 mm	No.	7		
B	- 1200 x 2700 mm double leaf Complete with 1.6mm thick anti-radiation lead plate sandwich - X-Room Door	No.	1		
	Doors, frames and finishings in wrought cypress				
	Glazing beads with two labours				
C	- 25 x 23 mm	LM	17		
	Beads with two labours				
D	- 25 x 25 mm	LM	51		
	Architraves with two labours				
E	- 50 x 38 mm	LM	51		
	Transome with three labours				
F	- 100 x 50 mm	LM	6		
	Frame with three labours				
G	- 200 x 50 mm	LM	51		
	Steel Casement French doors				
	Supply, assemble and fix the following purpose-made standard 32mm "Z" section steel doors to comply to B.S. 990, obtained from an approved manufacturer, primed with red oxide primer before delivery to site complete with hinges, handles, catches and building in lugs as detailed on drawings with all necessary frames & ironmongery.				
H	- 1500 x 2700 mm - Double Leaf	No	1		
I	- 900 x 2700 mm	No	1		
	Element 09				
	Doors	Carried Forward		Kshs.	

PROPOSED ERECTION AND COMPLETION OF RADIOLOGY UNIT AT NDARAGWA HEALTH CENTRE

Item	Description of Works	Unit	Qty	Rate	Amount (Kshs)
	Brought Forward			Kshs.	
	Ironmongery - supply and fix the following or other equal and approved with matching screws				
A	Pairs brass butt hinges - 100 mm	No	14		
B	Three lever stainless steel cylinder deadlock complete with handle - "Union 7203 SSS"	No	8		
C	Oval Satin anodised aluminium door stop [Ref: Union DS-01AS]	No	8		
	Clear sheet glass				
D	4 mm Glass and glazing to wood with beads [measured separately] in panes - 0.50 to 1.00 square metres	SM	2		
	Prepare and apply one coat wood preservative to woodwork before fixing				
	Frames , skirtings , etc.				
E	- not exceeding 100 mm	LM	68		
F	- 100 to 200 mm girth	LM	57		
G	- 200 to 300 mm girth	LM	51		
	Prepare and spray stain three coats polyurethane varnish to woodwork				
	Surfaces				
H	- not exceeding 100 mm	LM	68		
I	- 100 to 200 mm girth	LM	57		
J	- 200 to 300 mm girth	LM	51		
	Element 09				
	Doors	Carried to Summary		Kshs.	

PROPOSED ERECTION AND COMPLETION OF RADIOLOGY UNIT AT NDARAGWA HEALTH CENTRE

SUMMARY OF SECTION			
	Element number and name	Page	
01	Preliminaries	RU/1	
02	Substructures	RU/3	
03	R. C. Superstructure	RU/4	
04	Walling	RU/5	
05	Roof Structure & Covering	RU/7	
06	External Finishes	RU/8	
07	Internal Finishes	RU/9	
08	Windows	RU/10	
09	Doors	RU/12	
TOTAL FOR RADIOLOGY UNIT CARRIED TO SUMMARY		KSHS	

SERVICES

PROPOSED ERECTION AND COMPLETION OF RADIOLOGY UNIT AT NDARAGWA HEALTH CENTRE

Item	Description of Works	Unit	Qty	Rate	Amount (Kshs)
	ELEMENT 01 ELECTRICAL INSTALLATIONS				
A	Provide for installing mains connection and main switchboards, distribution boards and circuits, power and lighting installations, fire alarm system, telephone conduits a Prime cost Sum of shillings One million	Item	1	1,000,000	1,000,000
	Electrical Fittings				
B	Provide for Electrical Fittings a Prime Cost Sum of shillings Five hundred Thousand	Item	1	500,000	500,000
	Structured Cabling Installations				
C	Provide for Structured Cabling Installations a Prime Cost Sum of shillings Three hundred Thousand	Item	1	300,000	300,000
	Builder's Work in connection with Electrical installation				
D	Provide for Builder's work in connection with Electrical Installations	Item	1		
	Element 01				
	Electrical Installations		Carried to Summary	Kshs.	

PROPOSED ERECTION AND COMPLETION OF RADIOLOGY UNIT AT NDARAGWA HEALTH CENTRE

Item	Description of Works	Unit	Qty	Rate	Amount (Kshs)
	ELEMENT 02 MECHANICAL INSTALLATIONS				
	Plumbing, Drainage & Fire Fighting Installations				
A	Provide for Plumbing, Drainage & Fire Fighting Installations a Prime Cost Sum of shillings Three hundred thousand	Item	1	300,000	300,000
	Sanitary Fittings				
B	Provide for supply and installation of Sanitary Fittings a Prime Cost Sum of shillings Two hundred thousand	Item	1	200,000	200,000
	Mechanical Ventilation & Air - Conditioning Installations				
C	Provide for Mechanical Ventilation & Air - Conditioning Installations a Prime Cost Sum of shillings Five hundred thousand	Item	1	500,000	500,000
D	Provide for Builder's work in connection with Mechanical installations	Item	1		
	Element 02				
	Mechanical Installations	Carried to Summary		Kshs.	

PROPOSED ERECTION AND COMPLETION OF RADIOLOGY UNIT AT NDARAGWA HEALTH CENTRE

	<u>ELEMENT 03 - PROVISIONAL SUMS</u>				
	<u>The following provisional sums are to be measured on completion and priced in accordance with the rates contained in these bills of quantities or prorata thereto or deducted in whole if not required</u>				
A	Allow a provisional sum of Kshs One hundred and fifty Thousand (Kshs. 150,000.00) Only for Supervisory expenses	ITEM			150,000
B	Allow a provisional sum of Kenya shillings Five hundred thousand (Kshs. 500,000.00) Only for Contingencies to be expended in whole or part only at the discretion of the Project Manager	ITEM			500,000
	Element 03				
	Provisional Sums	Carried to Summary		Kshs.	650,000

PROPOSED ERECTION AND COMPLETION OF RADIOLOGY UNIT AT NDARAGWA HEALTH CENTRE

SUMMARY OF SECTION		Page	
	Element number and name		
01	Electrical Installations	SI/1	
02	Mechanical Installations	SI/2	
03	Provisional Sums	SI/2	650,000
TOTAL FOR SERVICES INSTALLATIONS CARRIED TO SUMMARY		KSHS	

PROPOSED ERECTION AND COMPLETION OF RADIOLOGY UNIT AT NDARAGWA HEALTH CENTRE

GRAND SUMMARY

ITEM	DESCRIPTION	Page No.	FOR OFFICIAL USE ONLY	FOR TENDERER USE ONLY
			KSHS.	KSHS.
A	Radiology Unit - Builder's Works	RU/13		
B	Electrical Installations	SI/1		
C	Mechanical Installations	SI/2		
D	P.C & Provisional Sums	SI/3	650,000.00	
	SUB-TOTAL			
	ADD 3% PROJECT MANAGEMENT PAYABLE TO COUNTY REVENUE ACCOUNT			
TOTAL CARRIED TO FORM OF TENDER INCLUSIVE OF 16% V.A.T.				

Amount in words. Kenya shillings

.....

Cents

Tenderer's Signature and stamp.....

Address

.....

Date

Witness Signature

Address

.....

Date

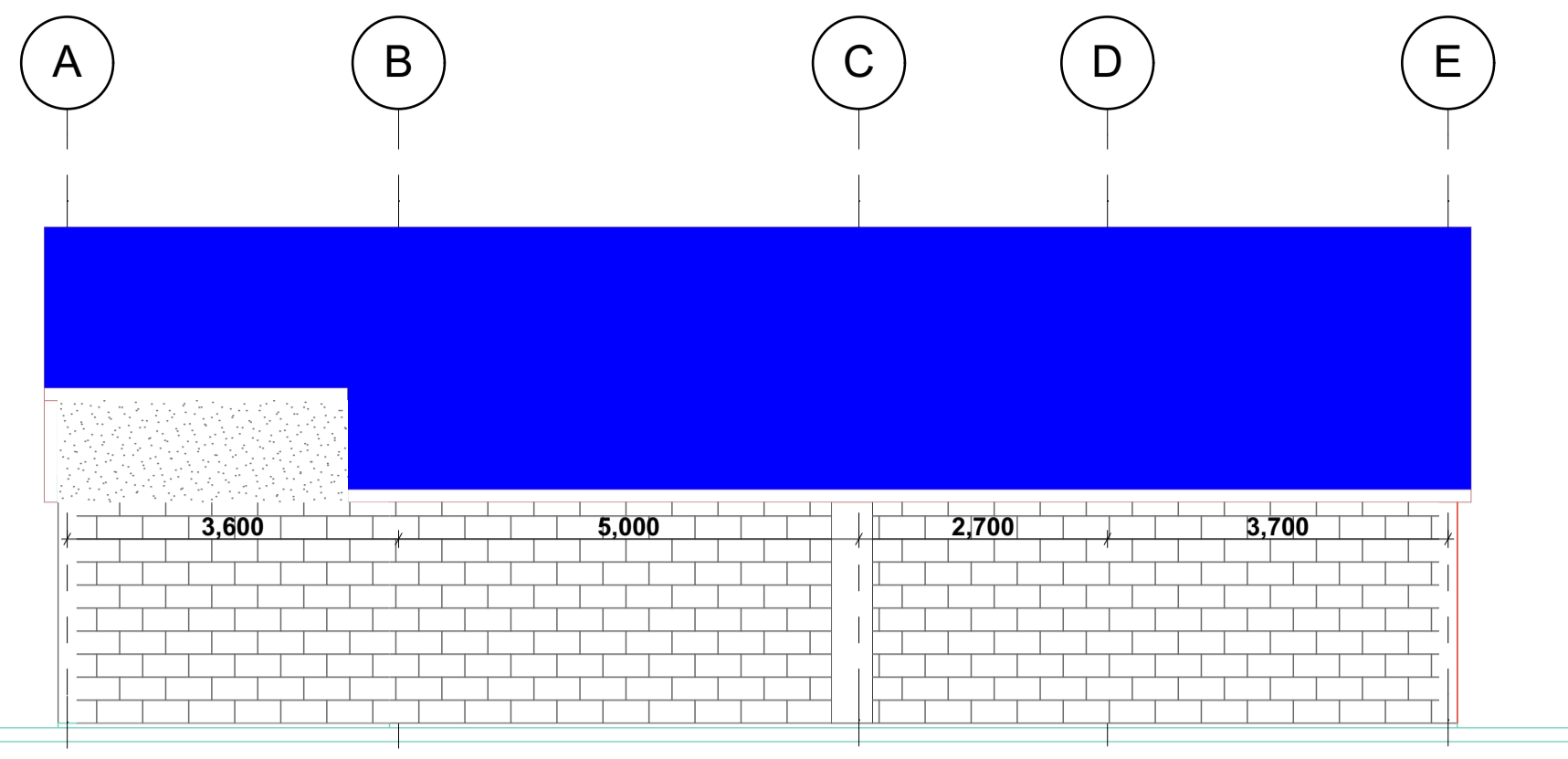

ELEVATION 01

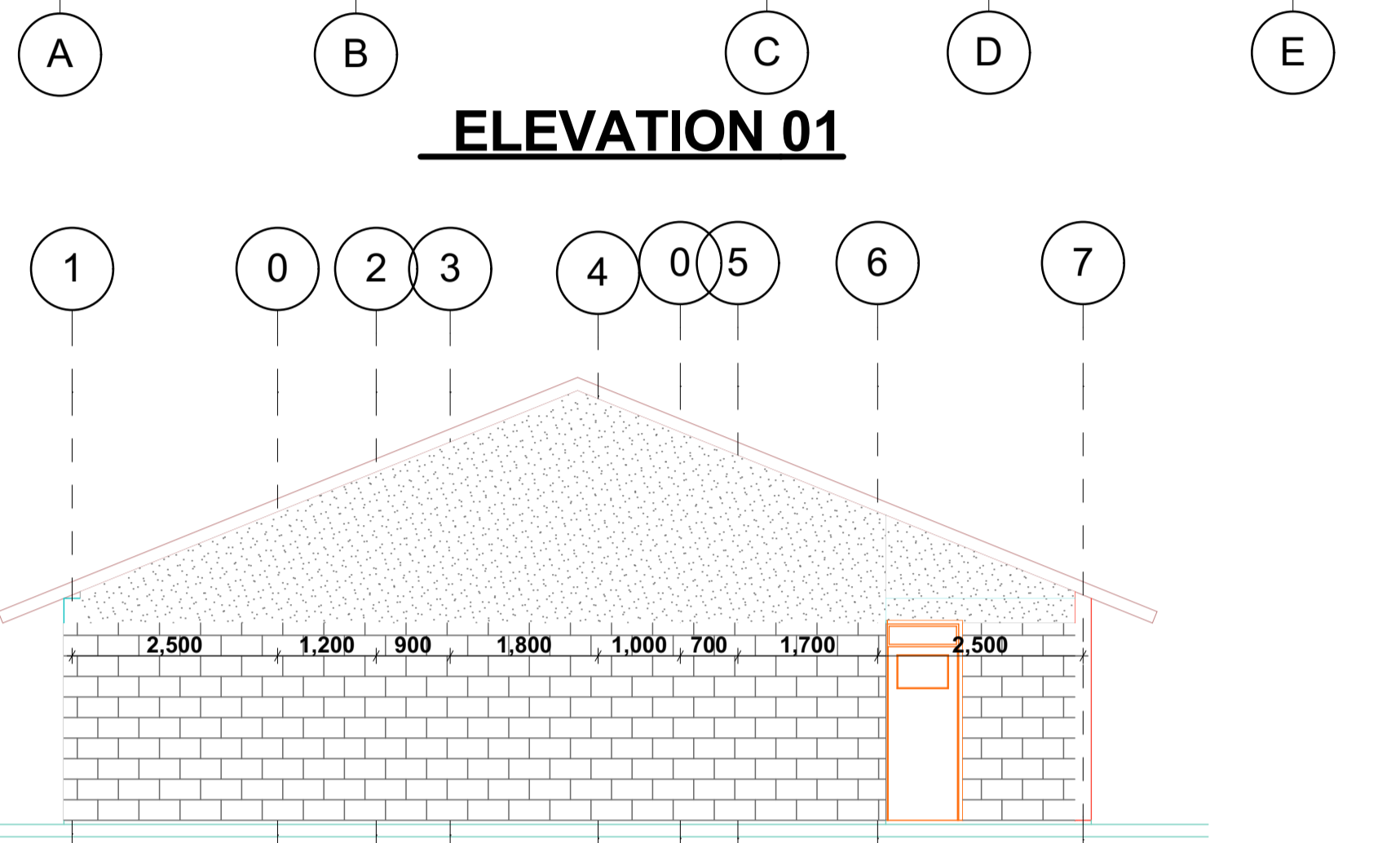

ELEVATION 02

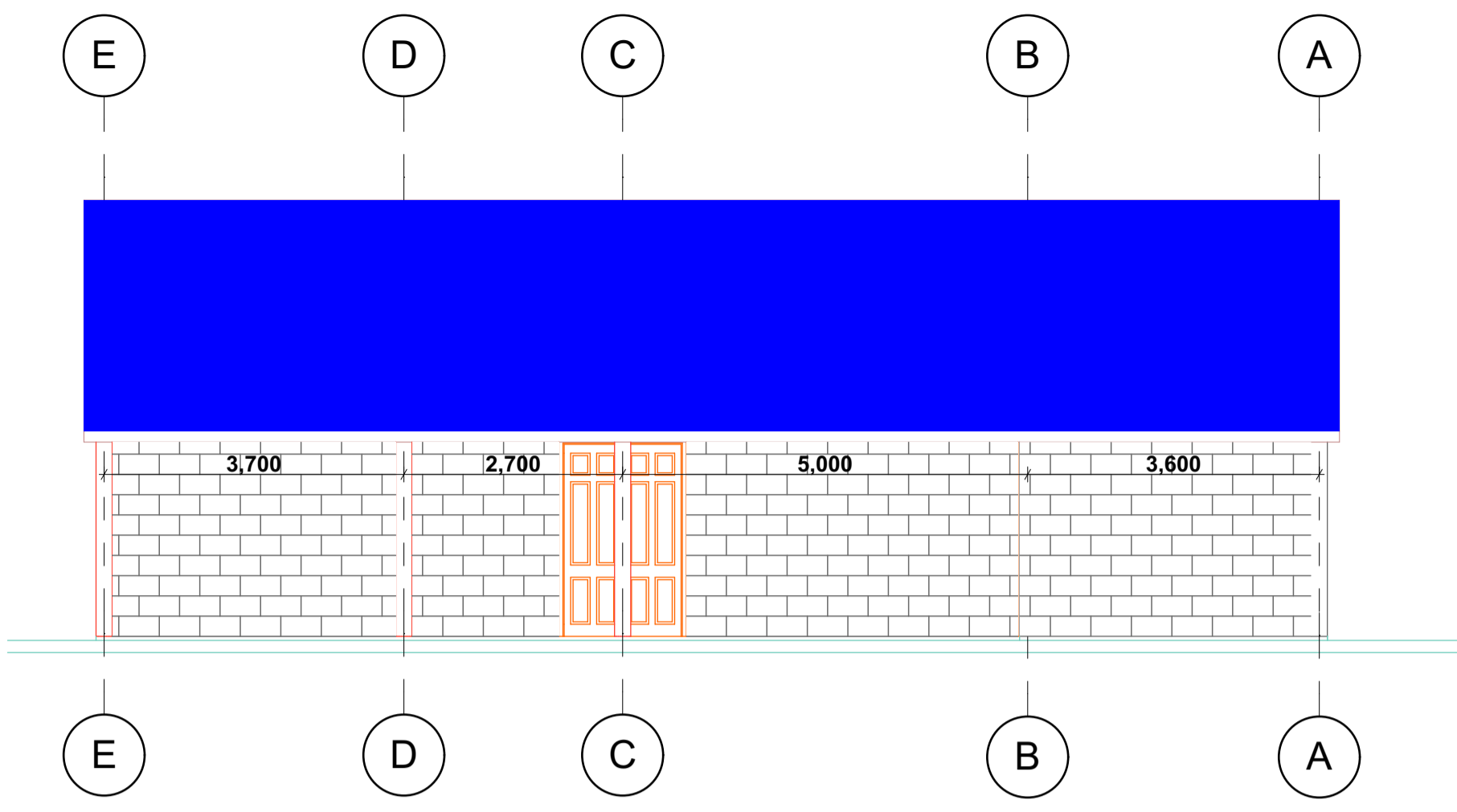

ELEVATION 03

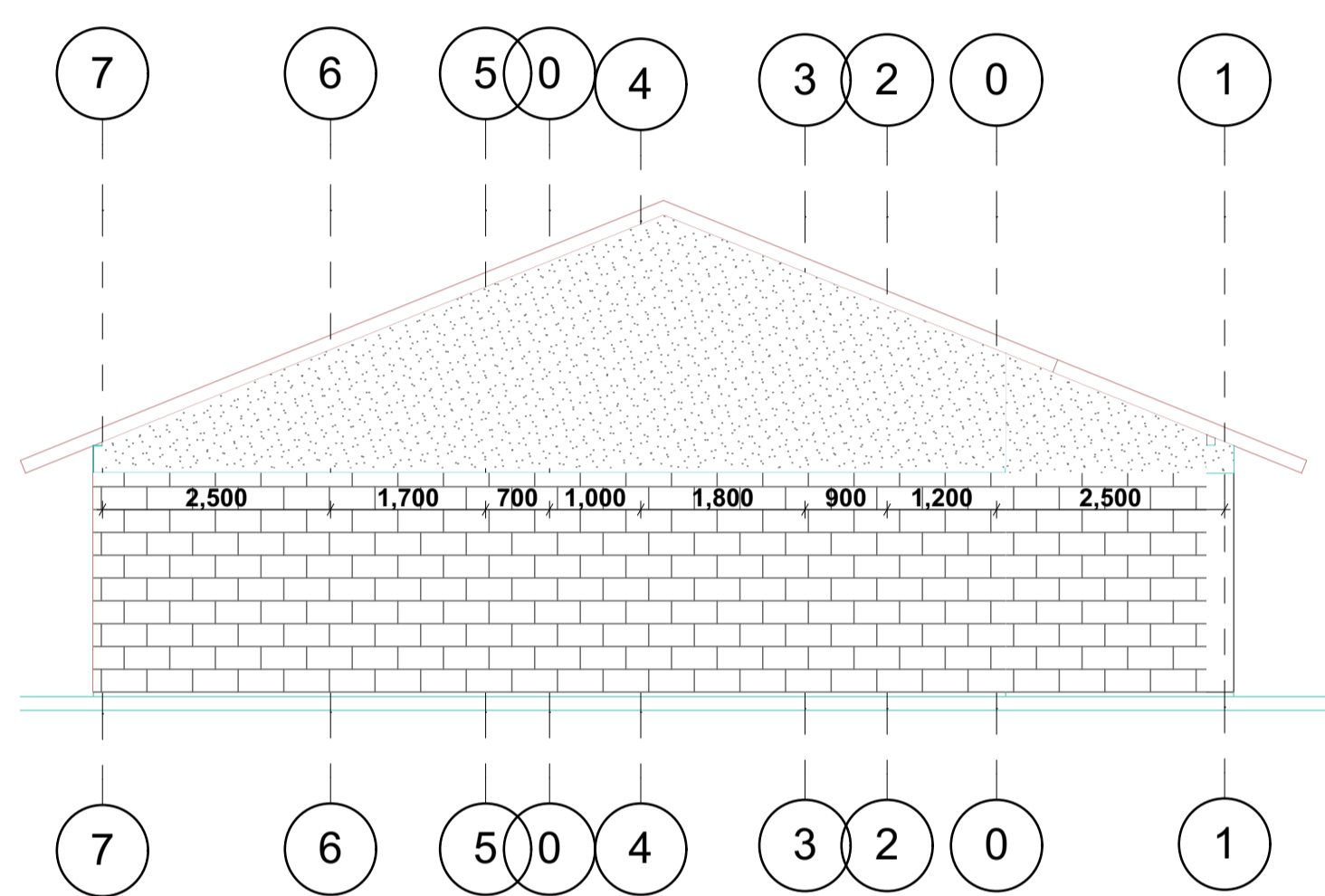

ELEVATION 04

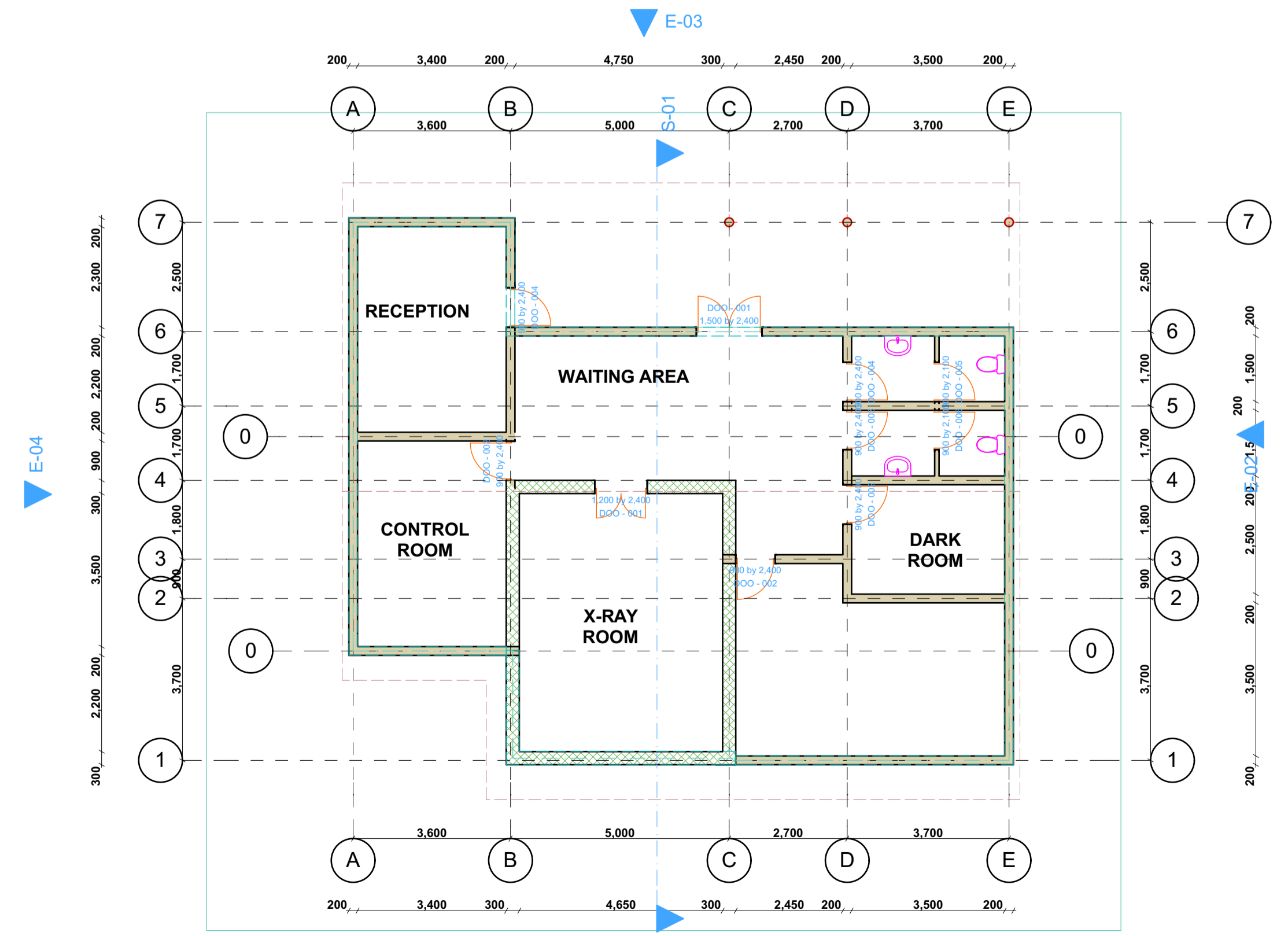

FLOOR PLAN LAYOUT

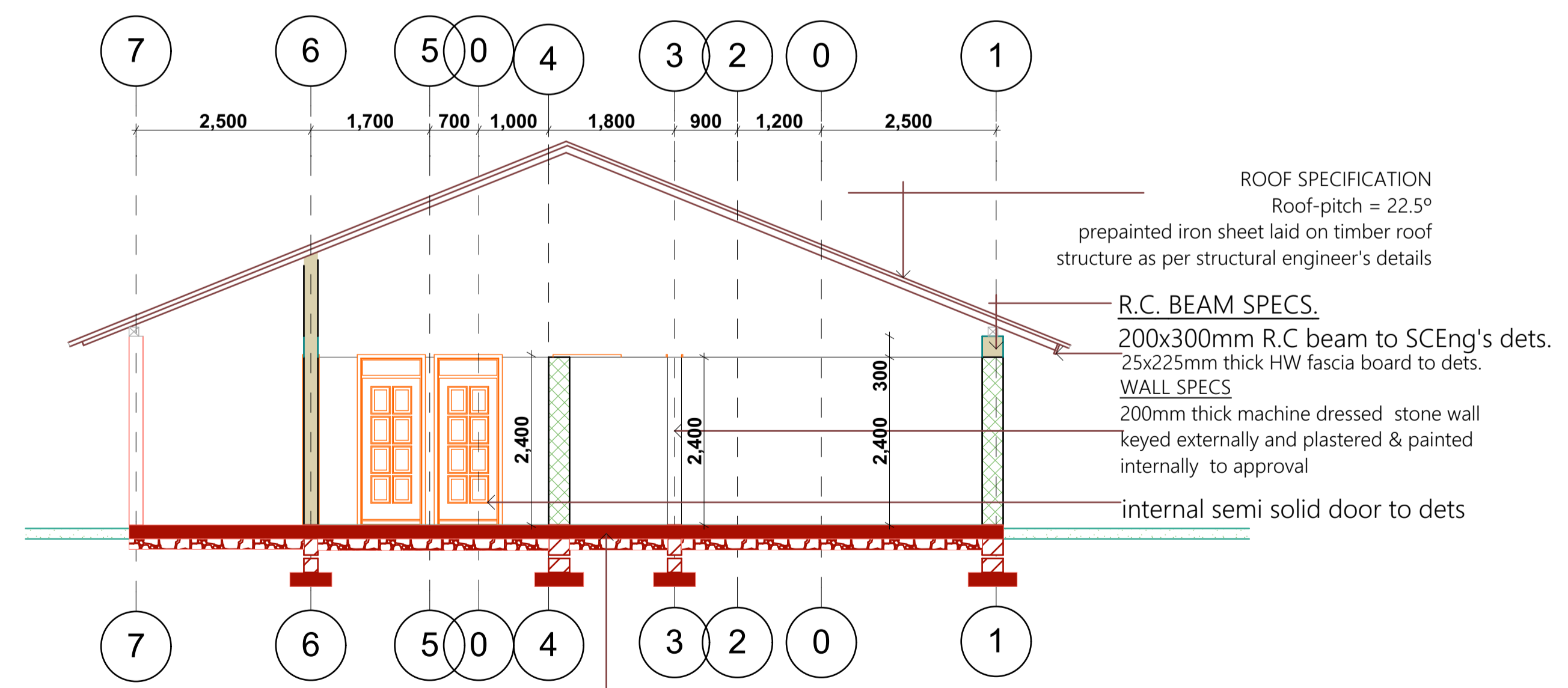

CONC. FLOOR SLAB SPECS.
 150mm thick conc. floor slab on 500gauge polythene D.P.M on 50mm thick blinding on compacted hardcore fill to approval +Termdor antitermite treatment

ROOF SPECIFICATION
 Roof-pitch = 22.5°
 pre-painted iron sheet laid on timber roof structure as per structural engineer's details

R.C. BEAM SPECS.
 200x300mm R.C beam to SCEng's det's.
 25x225mm thick HW fascia board to det's.

WALL SPECS
 200mm thick machine dressed stone wall keyed externally and plastered & painted internally to approval

internal semi solid door to det's

SECTION 01

NOTES

- All dimensions are in millimetres unless specified otherwise.
- All dimensions are to be read and not scaled/measured.
- All masonry walls are to be reinforced with hoop iron at every alternate course.
- All works to be executed in accordance with the local authority by-laws and relevant building codes and regulations.
- D.P.C. to be provided for all ground floor masonry walling.
- Provide permanent vents to all openings.
- Any discrepancy to be reported to the designer.
- Foundation depths to be determined on site.
- All works to be executed under supervision of a qualified resident engineer or architect.
- Structural concrete to be class 25 (1:1.5:3) unless specified otherwise.
- minimum covers to be
 - stair, slabs and wall =20mm.
 - beams main bars =30mm.
 - columns main bars =40mm.
 - foundation =50mm.
- All tensile steel(Y) AND mild steel (R) to be in accordance with BS 4449 and fabric mesh to be in accordance with BS4483.
- Minimum laps to be 55 times the diameter unless otherwise stated.
- Nominal aggregate size to be 20mm.
- Indemnity:the designer will not be liable for poor workmanship, poor methods of construction, poor quality materials by the contractor.

REVISION	DATE	REMARKS
1.		
2.		
3.		
4.		

PROJECT:
PROPOSED X-RAY BLOCK

CLIENT:
HEALTH DEPARTMENT

DRAWN BY:
MARY WAWERU

DRAWING TITLE: PLANS,
 SECTIONS, ELEVATION
 &DETAILS

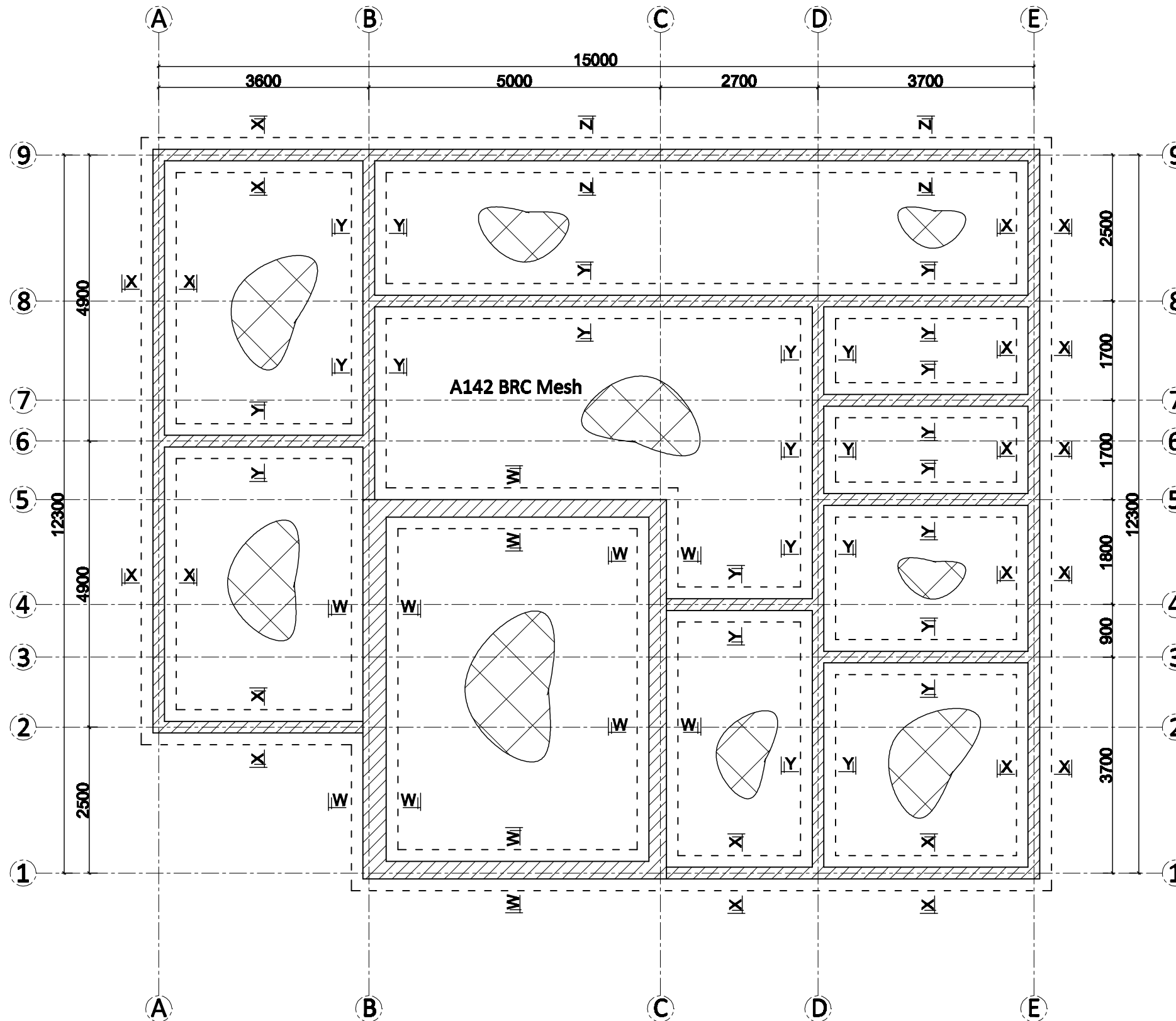

FOUNDATION LAYOUT
(Scale 1:75)

NOTES

- This drawing must be read in conjunction with architectural and any other relevant drawings.
- The Contractor must confirm all dimensions on site before commencing any work.
- All dimensions are in millimetres unless specified otherwise.
- Concrete cover to reinforcement steel to be:
Foundations: 50mm Columns: 40mm Beams: 25mm Slab: 20mm
- Concrete strength for structural concrete members to be class 20/20, (mix: 1:2:4 Cement : Sand : Coarse Aggregate)
- Square twisted steel reinforcement bars to B.S.4461 are denoted "Y".

- Mild steel reinforcement bars to B.S.4449 are denoted "R".
- All steel reinforcement MUST be approved by the Structural Engineer before casting.
- All steel to be well covered with an optimum moisture content of 10% to 15% to BS 6800.
- Concrete to be tested and approved by the Engineer before mass fabrication of the formwork.
- Top Surface Cover = 100mm
Reinforcement Cover = 100mm
Reinforcement Spacing = 100mm
Timber Spacing = 100mm
- Minimum beam spacing to be 100mm with joints closely spaced. Anchorage bolts - 12mm diameter, 50mm

long to be provided at intervals of 1000mm to anchor the wall plate in position.

ISSUES			
DATE	TO	APPLICATION	TO
REVISIONS			
No.	DATE	BY	DESCRIPTIONS
REFERENCE DRAWINGS			
No.	DESCRIPTIONS		

USER CLIENT
DEPARTMENT OF HEALTH SERVICES

JOB No.

PROJECT TITLE
PROPOSED X-RAY BLOCK FOR ENGINEER HOSPITAL

DRAWING TITLE
FOUNDATION LAYOUT & DETAILS.

C1/Sfb

DRG No. **STR-01**

FILE No.

SCALE(S)
1:75; 1:25

FIGURED DIMENSIONS ONLY TO BE TAKEN FROM THIS DRAWING

FOR THE GOVERNMENT OF THE REPUBLIC OF KENYA

NAME	SIGNATURE	DATE
DESIGN/DRAWN KAMAU M.		AUGUST 2014
CHECKED ENR. L. N. MURJI		AUGUST 2014

MINISTRY OF LANDS, HOUSING AND URBAN DEVELOPMENT PUBLIC WORKS NYANDARUA COUNTY

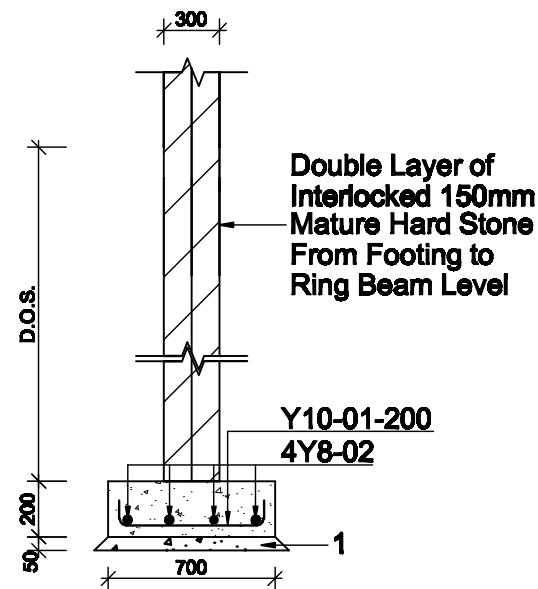

SECTION W-W
(Scale 1:25)

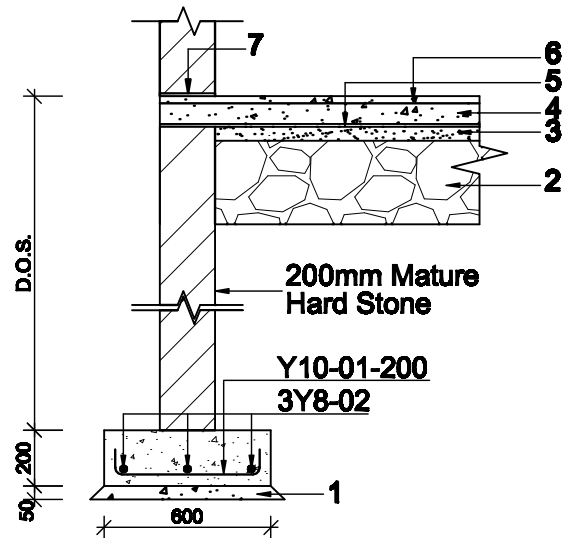

SECTION X-X
(Scale 1:25)

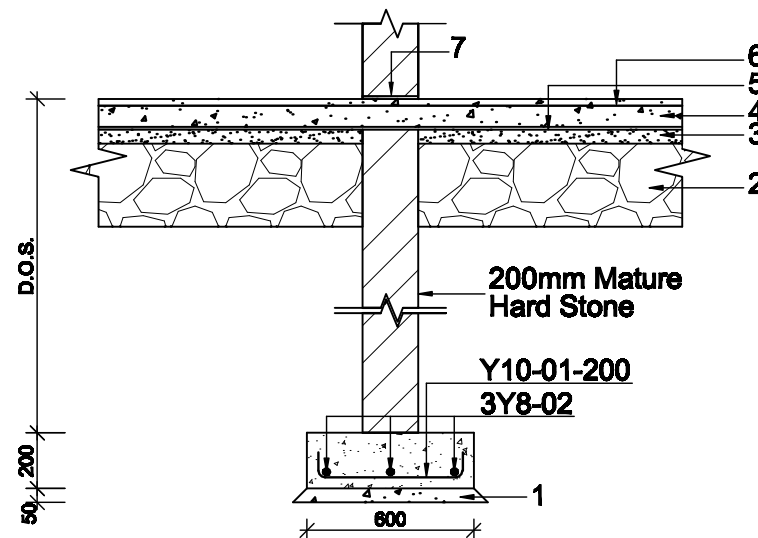

SECTION Y-Y
(Scale 1:25)

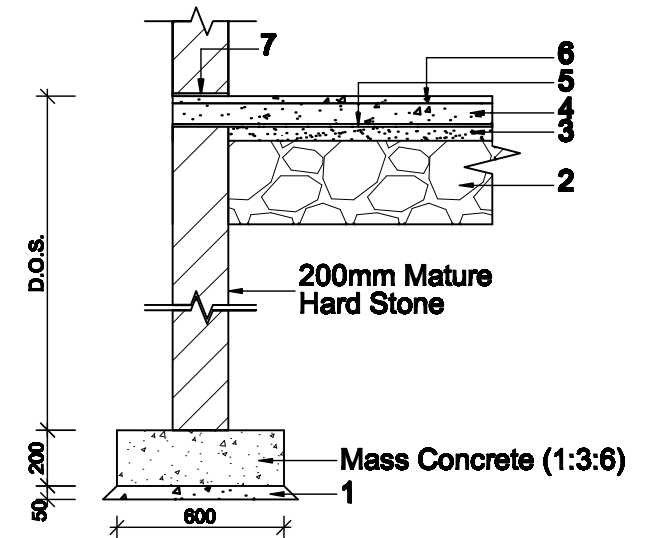

SECTION Z-Z
(Scale 1:25)

- KEY TO FOUNDATION**
- SECTION DETAILS:**
1. Blinding Concrete (1:4:8)
 2. 300mm Well Compacted Approved Hardcore (Compacted in layers of 150mm)
 3. 50mm Murrum Blinding
 4. 150mm Thick Floor Slab
 5. 500mm Gauge Damp Proof Membrane (DPM)
 6. A142 BRC Mesh (Placed 25mm from top of slab)
 7. Damp Proof Course (DPC)
- * Foundation depth to be determined on site but to a minimum of 1200mm and to firm bearing strata, Min: 100KN/M2

NOTES

1. This drawing must be read in conjunction with architectural and any other relevant drawings.
2. The Contractor must confirm all dimensions on site before commencing any work.
3. All dimensions are in millimetres unless specified otherwise.
4. Concrete cover to reinforcement steel to be:
Foundations: 50mm Columns: 40mm Beams: 25mm Slab: 20mm
5. Concrete strength for structural concrete members to be class 20/20, (mix: 1:2:4 Cement: Sand: Coarse Aggregate)
6. Square twisted steel reinforcement bars to B.S.4461 are denoted "Y".

7. Mild steel reinforcement bars to B.S.4449 are denoted "R".
8. All steel reinforcement MUST be approved by the Structural Engineer before casting.
9. All steel to be well covered with 25mm concrete with an optimum moisture content of 10% - 15% to BS 5100-2:1977
10. Sample Testers to be provided and approved by the Engineer before mass fabrication of the steel:
Top Surface Cover = 100mm
Bottom Cover = 100mm
End Cover = 100mm
Timber Spacing = 100mm
11. Minimum trans spacing to be 100mm with joints closely spaced. Anchorage bolts - 12mm diameter, 50mm

long to be provided at intervals of 1000mm to anchor the wall plate in position.

ISSUES			
DATE	TO	APPLICATION	TO
REVISIONS			
No.	DATE	BY	DESCRIPTIONS
REFERENCE DRAWINGS			
No.	DESCRIPTIONS		

USER CLIENT
DEPARTMENT OF HEALTH SERVICES

JOB No. _____

PROJECT TITLE
PROPOSED X-RAY BLOCK FOR ENGINEER HOSPITAL

DRAWING TITLE
FOUNDATION LAYOUT & DETAILS.

C1/Sfb

DRG No. **STR-02**

M.o.L.H&U.D

FILE No. _____

SCALE(S)
1:75, 1:25

FIGURED DIMENSIONS ONLY TO BE TAKEN FROM THIS DRAWING

FOR THE GOVERNMENT OF THE REPUBLIC OF KENYA

NAME	SIGNATURE	DATE
DESIGN/DRAWN KAMAU M.		AUGUST 2014
CHECKED ENR. L. N. MURJI		AUGUST 2014

MINISTRY OF LANDS, HOUSING AND URBAN DEVELOPMENT
PUBLIC WORKS
NYANDARUA COUNTY

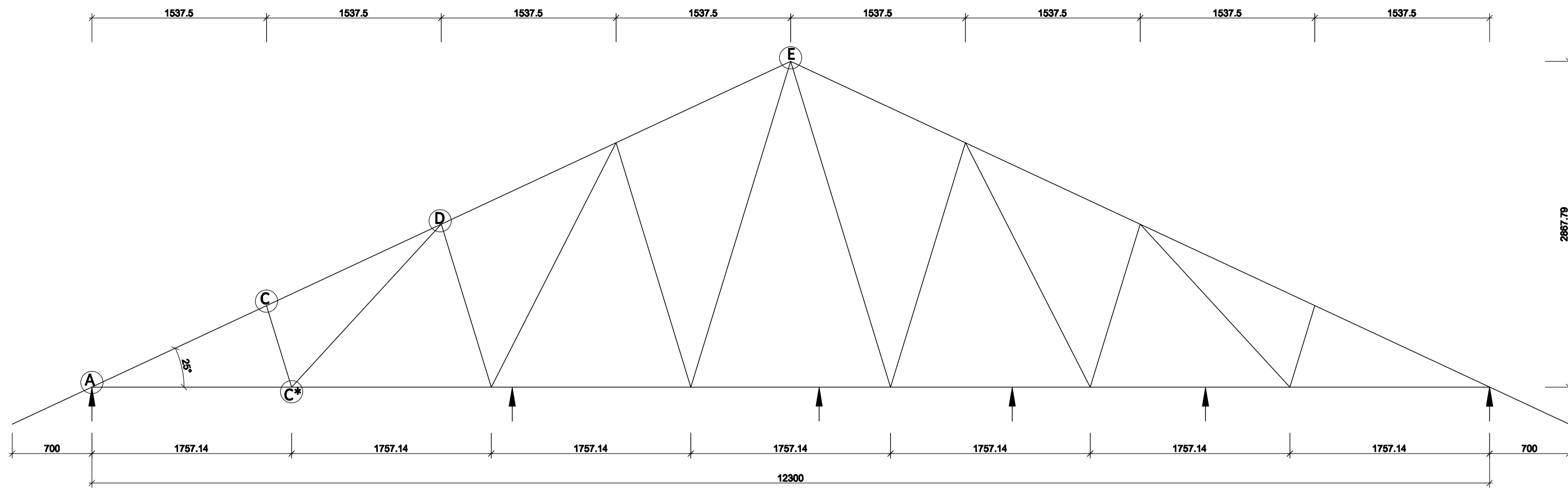

TRUSS TYPE T1 (8No.)
All Members - 100x50mm
(Scale 1:25)

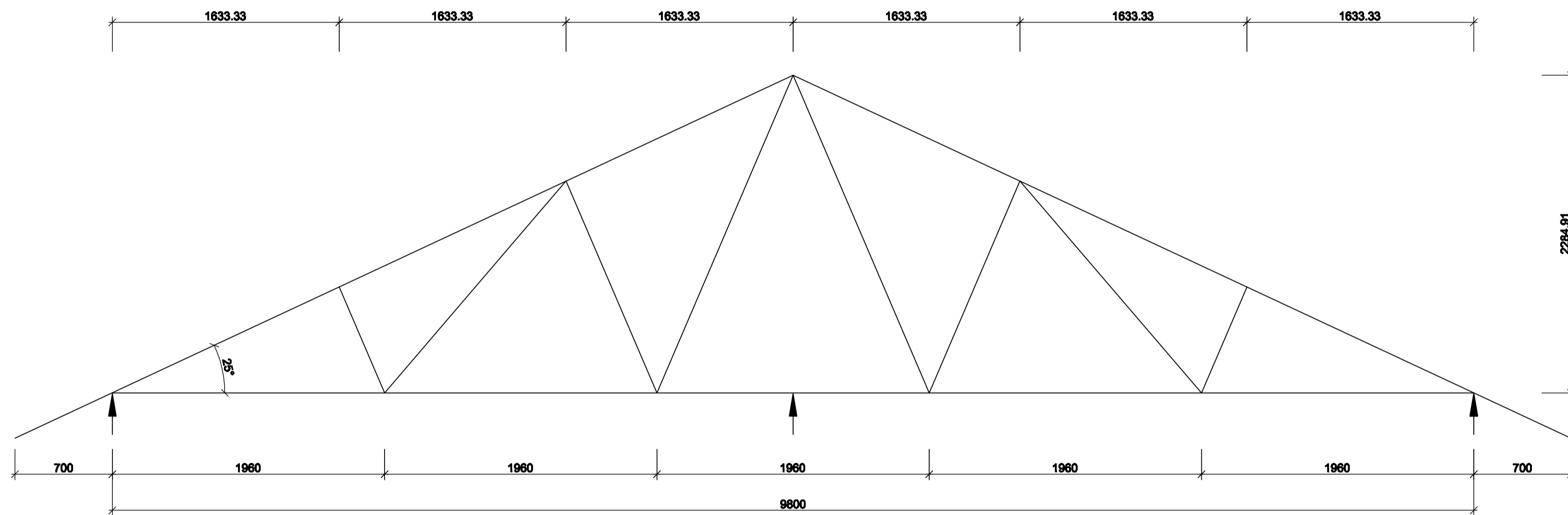

TRUSS TYPE T2 (3No.)
All Members - 100x50mm
(Scale 1:25)

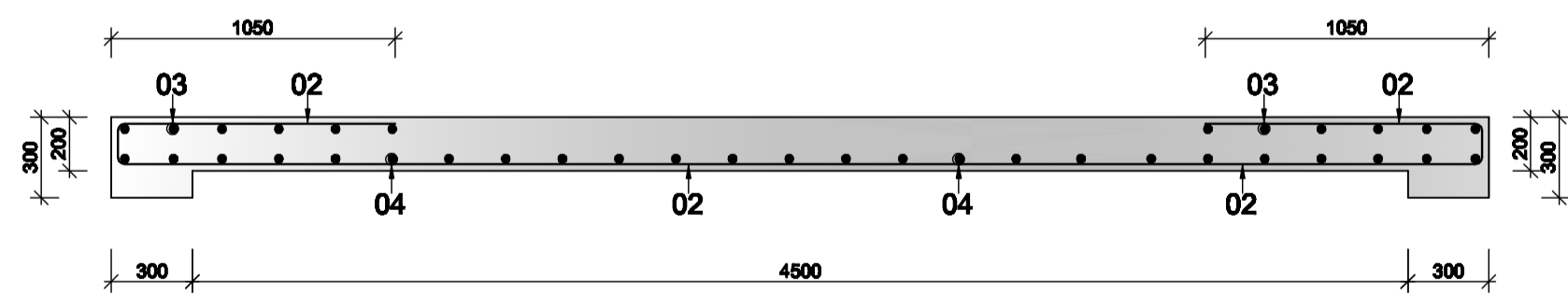

ROOF SLAB SECTION X-X
(Scale 1:25)

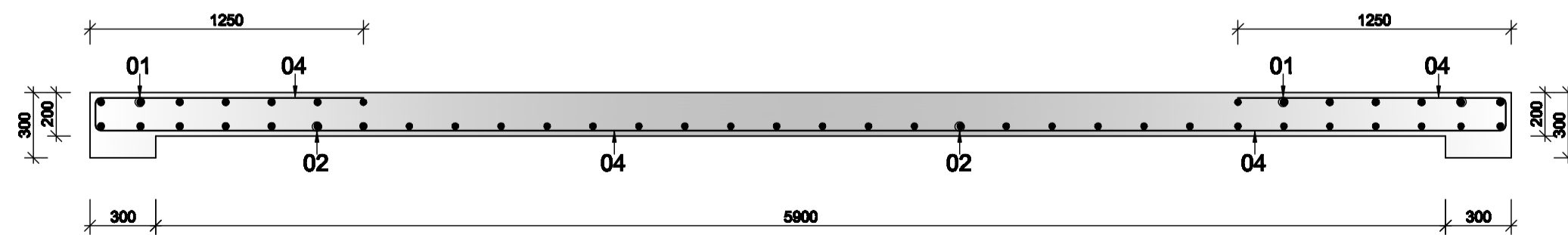

ROOF SLAB SECTION Y-Y
(Scale 1:25)

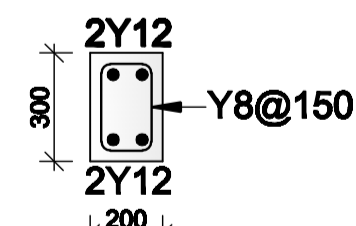

RBM 1 300x200
(Scale 1:25)

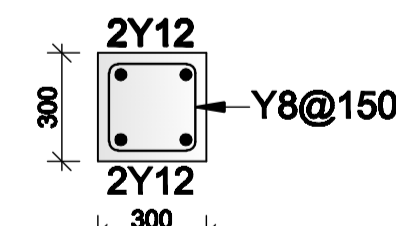

RBM 2 300x300
(Scale 1:25)

X-RAY ROOM ROOF SLAB (200mm THICK)
(Scale 1:50)

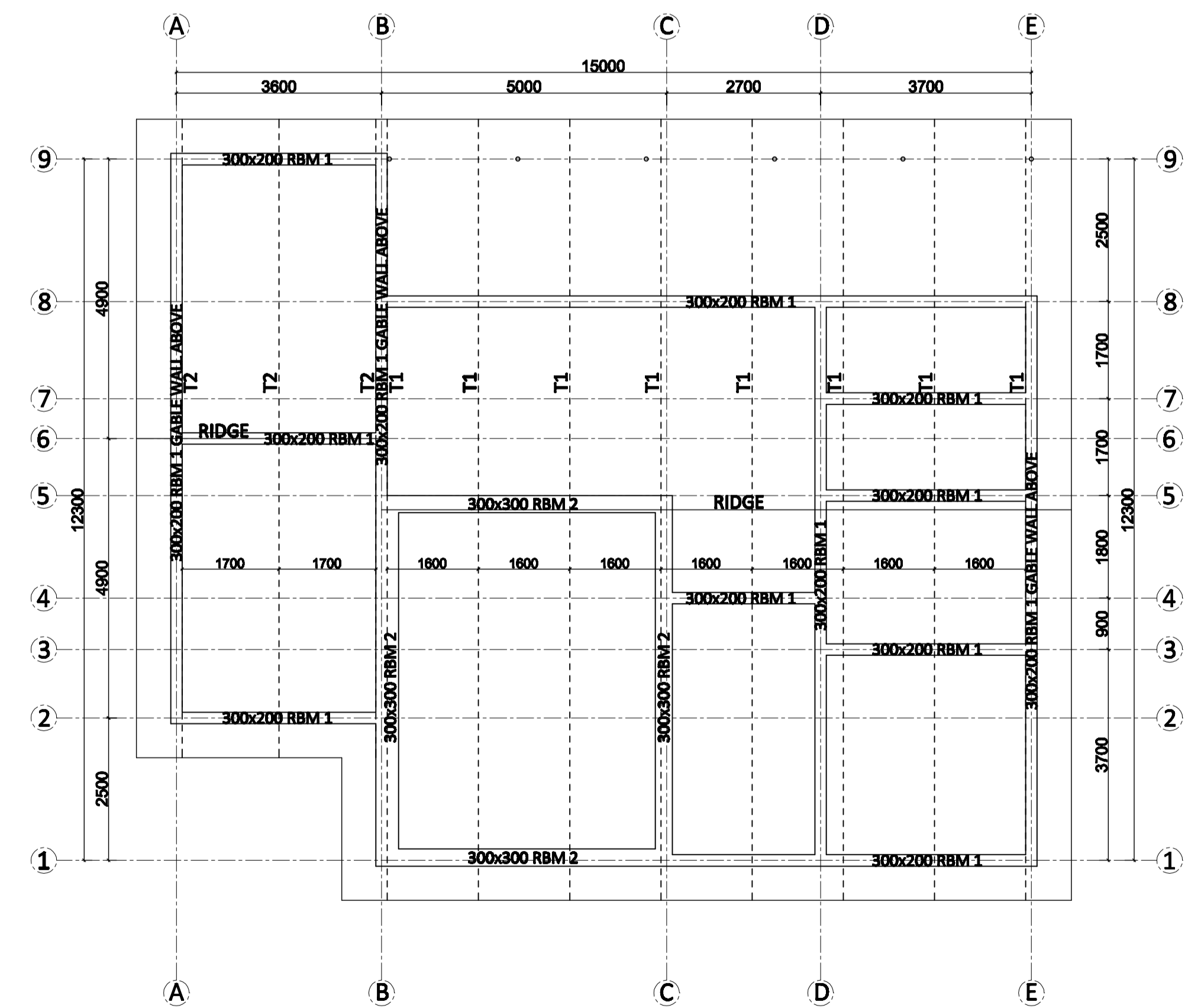

ROOF LAYOUT
(Scale 1:75)

NOTES

- This drawing must be read in conjunction with architectural and any other relevant drawings.
- The Contractor must confirm all dimensions on site before commencing any work.
- All dimensions are in millimetres unless specified otherwise.
- Concrete cover to reinforcement steel to be: Fdn = 50mm, Columns = 40mm, Beams = 25mm, Slab = 20mm.
- Concrete strength for structural concrete members to be class 20/20, (mix 1:2:4 Cement : Sand: Coarse Aggregate)
- Square twisted steel reinforcement bars to B.S.4461 are denoted "Y".

- Mild steel reinforcement bars to B.S.4449 are denoted "R".
- All steel reinforcement MUST be approved by the Structural Engineer before casting.
- All excavation work to be inspected and approved by the Structural Engineer before concreting.
- Assumed bearing Capacity = 100KN/M2

ISSUES			
DATE	TO	APPLICATION	TO
REVISIONS			
No.	DATE	BY	DESCRIPTIONS
REFERENCE DRAWINGS			
No.	DESCRIPTIONS		

USER CLIENT DEPARTMENT OF HEALTH SERVICES	JOB No.
PROJECT TITLE PROPOSED X-RAY BLOCK FOR ENGINEER HOSPITAL	
DRAWING TITLE ROOF LAYOUT AND DETAILS	

C1/Stb	DRG No. STR - 03
M.O.L.H&U.D.	FILE No.
SCALE:	FIGURED DIMENSIONS ONLY TO BE TAKEN FROM THE DRAWING
FOR THE GOVERNMENT OF THE REPUBLIC OF KENYA	

DESIGN/DRAWN	NAME	SIGNATURE	DATE
M. KAMAU	M. KAMAU		SEPT 2014
CHECKED	NAME	SIGNATURE	DATE
ENG. L. N. MUBILI	ENG. L. N. MUBILI		SEPT 2014
MINISTRY OF LAND, HOUSING AND URBAN DEVELOPMENT DIRECTORATE OF PUBLIC WORKS NYANDARUA COUNTY			

